

PRODUCT CATALOGUE



Galebreaker[®]

— A G R I —

Your Guard Against the Elements

01531 637900

www.galebreaker.com

	Page
Clip-on System	
Bayscreen	14
Rollerscreen	16
Rollerdoor	18
Agridoor Manual	20
Agridoor Electric Basic	22
Agridoor Electric Comfort	24
Agridoor Electric Premium	25
Agridoor Plus	26
Maxidoor	28
Multibay	30
Trackscreen	32
Door Systems	
VentTube Fresh	34
VentTube Cool	36
VVS Systems Overview & Options	38
VVS Rolling	39
VVS Climbing	40
VVS Drop	41
VVS Shade	42
VVS Controllers	43
iSeries	46
Light Ridge	48
Ventilation Control Systems	
Farmflex	50
Stockshade	51
Rigitex	51
Birdnet	51
PVC Strip	51
Sila-Cover 300	52
Fixed Systems	
Customer Services	53



10 Year Guarantee

Galebreaker's 10 year system guarantee includes all products in our door, clip-on panel and variable ventilation curtain ranges. Fans, motors, and system controllers are fully guaranteed for 3 years.

Galebreaker's VentTube range is fully guaranteed for three years; this includes the fan, tube and retraction system.

For more details about the guarantee visit www.galebreaker.com/agriculture/instructions-guarantees-2/



Website Support

Our website provides links to all our pre-installation and installation instructions, all found on the specific product pages.

www.galebreaker.com

Follow us on YouTube, Facebook, LinkedIn and Twitter for the latest product developments, industry news and seasonal promotions.



search:
galebreaker



/galebreakeruk



/company
/galebreaker-limited



/GalebreakerUK

Galebreaker

For more than 30 years, Galebreaker has been enabling agricultural businesses to perform at their best in any weather or climate. Our weather protection, ventilation and access solutions help provide ideal housing conditions for healthy, productive livestock.

Galebreaker was established in 1984 by the Scudamore family. In the three and a half decades that have followed the brand has become recognised as a sign of quality, reliability and value, not just in the UK but across the world. Our company values reflect the way we do business and the value of the family who founded and continue to lead Galebreaker.



Integrity



Reliability



Service



Leadership



Research and Development

We invest heavily in market research, prototype testing, field trials and data analysis to ensure that every product we put on the market delivers extraordinary value to our end users. The constant focus of our dedicated team is to design products that are able to withstand the harshest environmental conditions. Using our unique 4-stage product development cycle and leveraging AGILE project management, we are constantly pushing the boundaries of what is possible for ourselves and our clients.

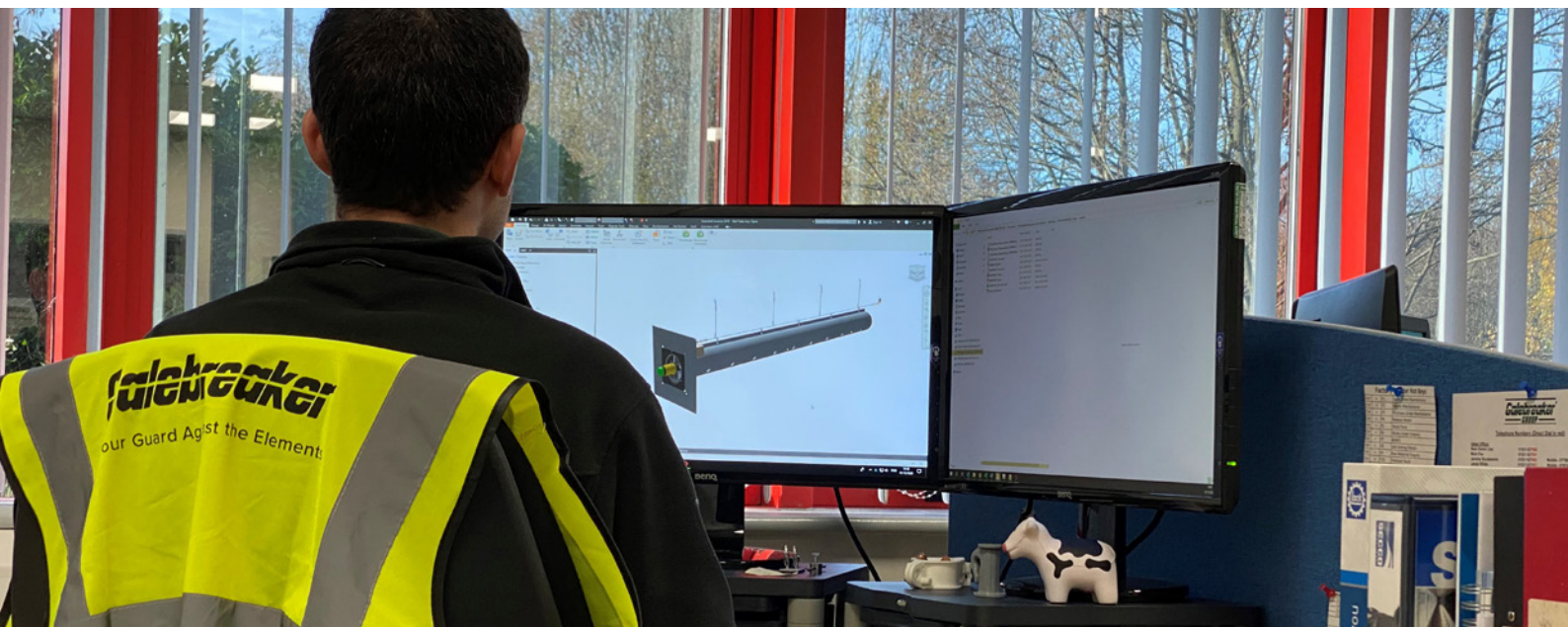

Leading the way to Industry 4.0

The world is changing. Smart technology and automation are being adopted by all industries, and the wealth of data available from these systems is transforming the way we and our customers do business. Galebreaker is at the forefront of these new technologies and believes this brings further benefits to our product range. The ability for our products to not only be controlled automatically, but for them to be part of a fully integrated system whereby, Galebreaker and third party products can interact and provide the customer data to make more informed decisions and realise efficiency savings, is now within our grasp.

Dairy

The very first Galebreaker was designed and developed for use on the Scudamore's dairy farm. Our product portfolio has grown over the last 35 years to encompass the very latest technology in fully automated variable ventilation systems and smart farm building control.

We understand the challenges of the dairy sector, both in our home market of the UK, across Europe and further afield.



Heat Stress

With warmer and more extreme temperatures, the topic of heat stress has been receiving greater focus. A large body of evidence suggests that heat is associated with lower milk yields, depressed feed intakes, reduced fertility and increased risk of mastitis – all of which affect profitability and animal welfare.

Our knowledgeable sales team and network of dealers will be able to advise you on the best solution for your livestock building. **Did you know that Galebreaker mesh allows substantially more natural air and light into a building than traditional wooden or metal cladding options?**

Building ventilation can be increased by replacing side walls, with clip on Bayscreens or a Variable Ventilation System, which can be automatically controlled to provide ventilation and weather protection depending on the weather conditions.

Building on the success of VentTube Fresh, Galebreaker has designed a positive pressure tube ventilation system, VentTube Cool, for cooling cows. **Tubes can be placed over cubicles to increase lying times, or over parlours or waiting areas to provide cooling and increase cow comfort.**

Dr. Bertjan Westerlaan at Vetvice, said: “VentTube Cool is an efficient way to cool cows and to provide clean and fresh air for every cow in the barn. It will help your cows fight heat stress during the summer.”

Creating an environment for calves to thrive

Like all livestock, calves need a well ventilated environment to thrive – the key difference with calf housing is balancing temperature and ventilation without creating a draught. **Pneumonia is the most common reason for death and poor performance of youngstock and ventilation plays a key role in calf health.**

Typically, well designed positive pressure tubes reduce pneumonia treatments by 50-75% (Dairyland Institute). When designing a PPTV system, **it is vital that the fan and tube are calculated correctly** to achieve the right level of ventilation according to stocking density, age of youngstock and building dimensions – not taking these factors into account could result in an ineffective system or worse, creating a draught and chill.

Galebreaker offers M90 Higher Performance (HP) material, which is ideal for using in calf environments. HP provides a greater level of weather protection with its smaller gauge hole. HP is available in green, grey and black.

Take a look at this video of a Multibay manufactured in HP Green for calf housing in the UK.

Scan to see
the Multibay
in action

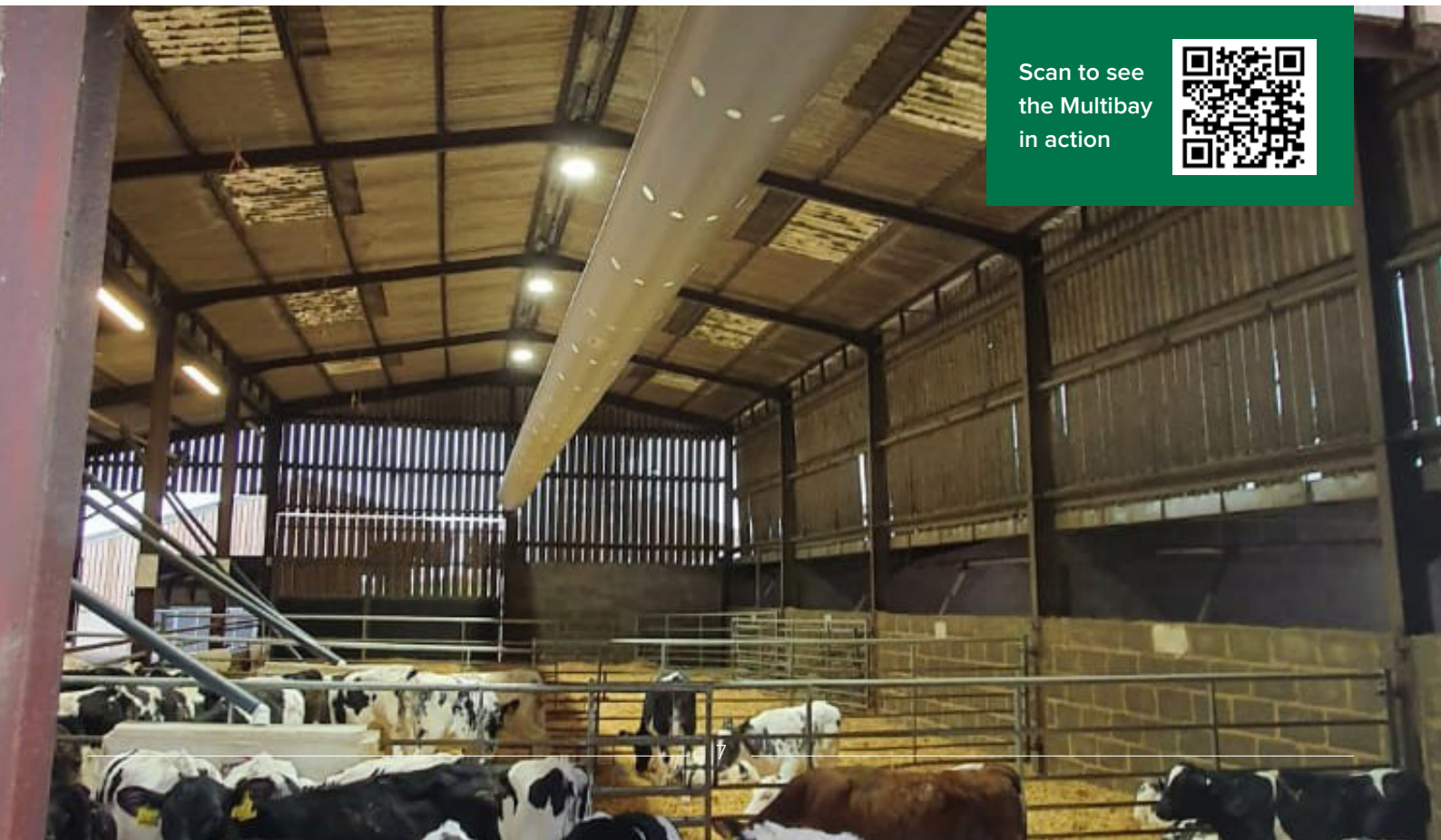

Pigs

Galebreaker is proud to be a long term partner of UK pig producers and equipment suppliers, specialising in straw bedded finishing units with a high emphasis on animal welfare.

With all our products being custom manufactured from our premises in Herefordshire, we can offer a number of fabric colours, depending on local planning constraints.

Creating the optimum environment

Temperature, humidity and light are all critical concerns for farmers trying to improve pig welfare. Pigs should be maintained within their thermo-neutral zones, with humidity between 60-80%, and with enough light to satisfy their behavioural and physiological needs.

Temperature impacts feed intake, feed conversion ratio and growth thus significantly impacting finishing weights. While there are a number of ventilation systems available, Galebreaker's Variable Ventilation side curtains offer a lower cost natural ventilation option. A well designed natural ventilation system will prevent draughts while allowing clean, fresh air into the building.





Fully automated control

Busy pig producers often have competing demands on their time and may not be available to constantly check housing conditions. Galebreaker's VVS side curtains are powered by VentLogic technology, our automatic control system that makes use of temperature, wind speed, wind direction and rain sensors ensuring that the climate within the building is continually optimised whether on farm or not.

Galebreaker has now taken this automation a step further with the development of an app-based controller which not only monitors and controls the building environment, but also collects a range of environmental data such as ammonia, humidity and temperature. More can be found on page 38.



Equine

Galebreaker's fabric allows substantially more light into the building than other cladding options – ideal for creating light and airy riding arenas and menages.

Bayscreens can be manufactured in a variety of fabric colours, to match the exterior of your building; spanning up to 20m in width, Bayscreen is easily fitted to building bays providing a semi-permanent screening option.

Stables can also suffer from poor ventilation increasing the risk of respiratory problems, VentTubes bring fresh air into a building and actively push out warm, stale air. VentTubes are made to measure and are ideal for older buildings, where other ventilation methods may not be suitable.

Good building design requires an inlet to bring fresh air into the building (for example ventilated side walls), and an outlet to exhaust the warm, stale air – Galebreaker's Light Ridge provides an open vent along the roof ridge, with the added benefit of using toughened PVC panels which increase natural light transmission.

Light Ridges can be added to riding arenas or stable blocks.





Weather protection for horse and rider

Galebreaker manufactures weather protection, ventilation and access solutions with both horse and rider in mind. Our Sales Teams and Dealer Network have decades of experience providing high quality equipment specifically to the equine market and will be able to assist you every step of the way. Whether you need weather protection for open spaces or ventilation systems for your stables, our equine products are designed to provide the highest levels of convenience, efficiency and animal welfare.



Smart Farm Building Control

Galebreaker's ongoing investment in R&D allows us to design products which meet the needs of the progressive farmer. We are leading the way in automated building control with our app which allows farmers to measure, monitor and control key aspects of their building environment.

Government led animal welfare legislation, coupled with increasing processor and consumer demands for total traceability within the supply chain, will undoubtedly lead to further pressure on the livestock industry to measure and monitor housing and growing conditions at all levels.





VentLogic iSeries

The VentLogic iSeries is an unprecedented leap in smart farm building control, designed to provide the optimal conditions for livestock health and growth. Powered by intelligent automation, the iSeries responds in real-time to changes in weather and environmental conditions to ensure the highest levels of productivity and animal well being.

Scan to see
the VentLogic
iSeries
in action



Bayscreen[®]

Clip-on fast fit panels with built-in ratchet tensioning system for permanent or temporary weather protection and ventilation.

- Easily installed and fully adjustable to fit available opening
- No additional supports necessary
- No drilling or bolting required
- Fit one above another to reach any height

Ideal for infrequent access, seasonal use, livestock buildings, and hay/straw storage buildings.



Heights at 1m, 1.5m, 2m and 3m | Widths from 3.05m to 20m



Self fit



Flexible weather protection



Fast fit



10 year warranty

Fast fit clip-on panels, ideal for infrequent access

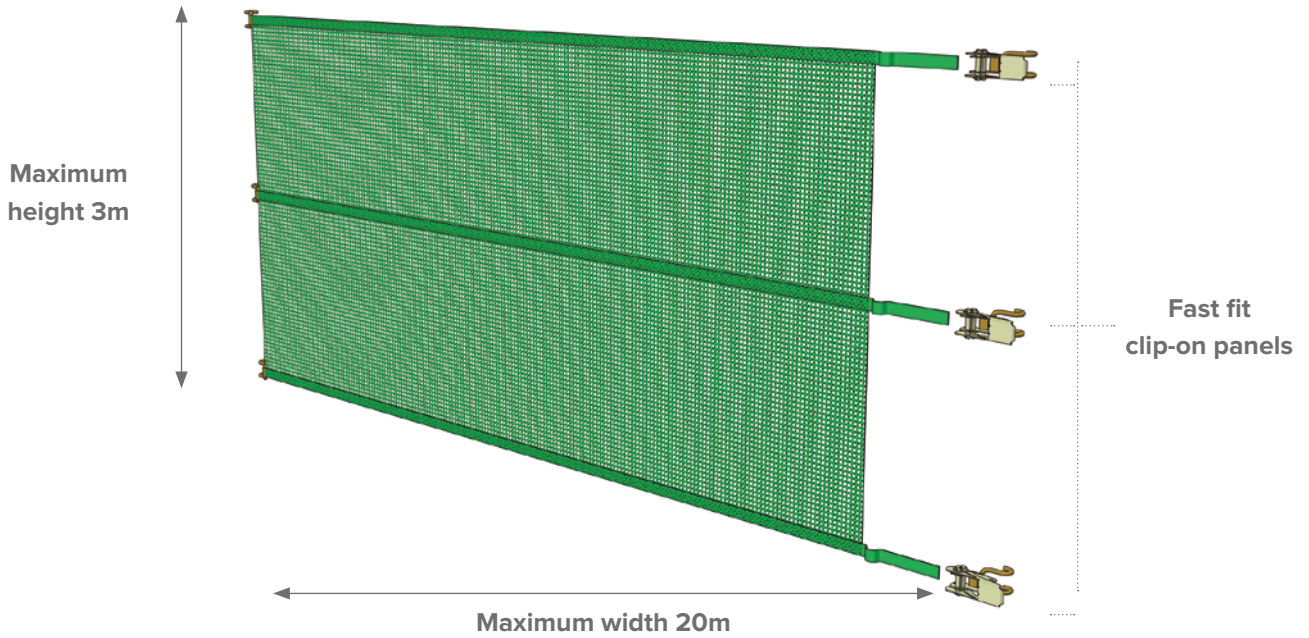

- Provides ventilation
- Tear and rot proof
- Robust hooks and ratchets included

- Range of colours
- Optional sliding track or trapezium shape

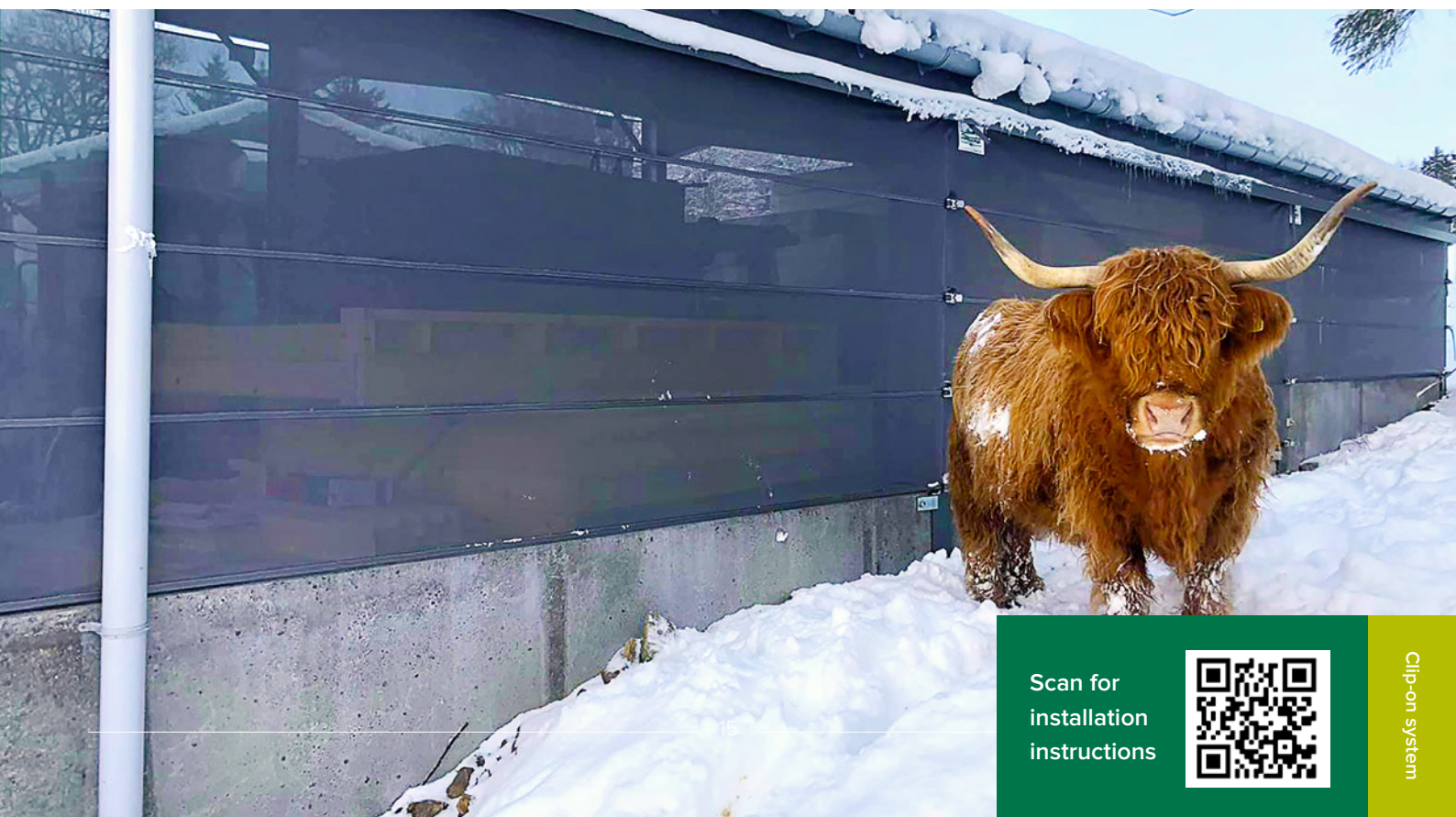

Scan for
installation
instructions



Rollerscreen

The Galebreaker Rollerscreen system is a spring-operated windbreak allowing for variable ventilation as well as weather protection. Designed to fit above gates, lower walls and feed barriers, Rollerscreen provides fast access to sheds and feed passages, and is fully adjustable to fit any opening. Market leader for over 30 years, the UK's best selling spring operated rollerscreen system. Designed and delivered in kit form for maximum ease of installation on farm.



Heights at 2.1m, 3.1m and 4.1m | Widths from 2.5m to 6m



**Fit above gates
or lower walls**



Self fit



**Regular access
required**



**10 year
warranty**

Spring operated roller screen system

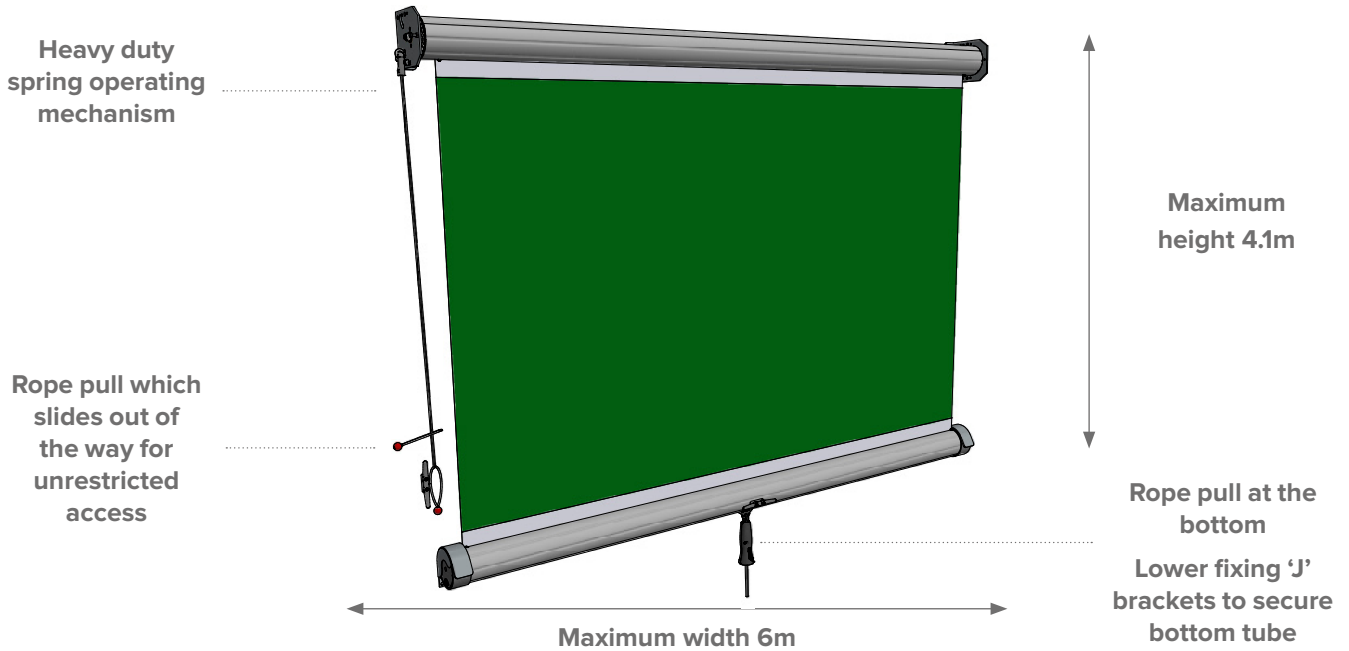

- Optional cowling for enhanced weather protection
- Range of colours available
- Additional lower fixing 'J' brackets available
- Spring tensioning
- Provides ventilation
- Tear and rot proof
- Unique locking mechanism



Scan for
installation
instructions



Rollerdoor

Fast opening, chain driven door – the safe, affordable alternative to large sheeted doors. Offers weather protection, whilst providing natural ventilation. Available in standard and high performance mesh, in a range of colours.



Heights at 3.1m, 4.1m, and 5.1m | Widths from 2.5m to 6m



**Economical,
manual farm
door**



Self fit



**Regular access
required**



**10 year
warranty**

Economical, full-height door

Spring assisted for safe operation



Direct chain drive for fast operation

Strong guiderails for added wind protection

- Sheets easily replaceable in case of damage
- Optional brushstrip to exclude insects and birds
- Optional cowling for enhanced weather protection



Scan for installation instructions



Agridoor Manual

An industry leading solution providing easy access to all types of farm buildings, the Agridoor Manual works on either the inside or outside of buildings. Ideal as a weather protected access solution for feed storage, grain storage, feed passages, parlours and general purpose farm buildings.

Door tested to 10,000 cycles giving confidence of long life.



Heights from 3m to 6m | Widths from 2.5m to 6m

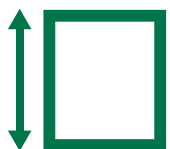

Fully adjustable



Self fit



Sectional door



10 year warranty

Sectional, fast operating door

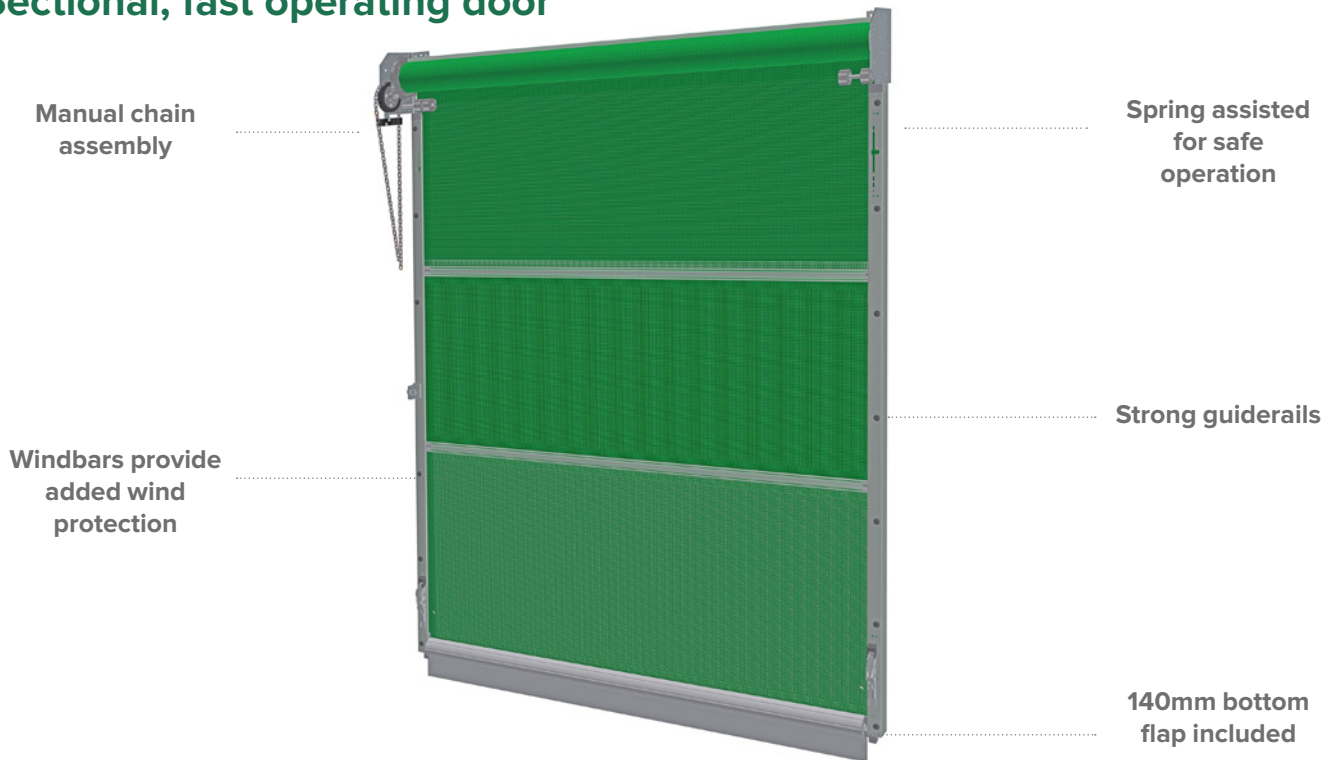

- Cowling available for enhanced weather protection
- Left or Right hand operation
- Solid and Mesh fabric options
- Choice of panels which can be replaced easily in event of accidental damage
- Optional bird proofing seals



Scan for
installation
instructions



Agridoor Electric

An industry leading solution providing easy access to all types of farm buildings, the Agridoor Electric provides all the advantages of the manually operated Agridoor but with an electric motor drive.

Operation speed 9sec/m. Agridoor Electric is available in Basic, Comfort (not available in the UK) or Premium options. Each giving different levels of operation from hold to run button to full remote control.



Heights from 3m to 6m | Widths from 2.5m to 6m

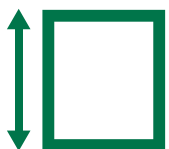

Fully adjustable



Self fit



Sectional door



10 year warranty

Agridoor Electric Basic - Sectional, fast operating door

Spring assisted for safe operation

Windbars provide added wind protection

Strong guiderails



Strong, single phase tubular motor giving opening speed of 9sec/m



Easy to operate hold to run switches

- Choice of panels which can be replaced easily in event of accidental damage
- Push button hold to run switches
- Cowling available for enhanced weather protection



Agridoor Electric Comfort*

Spring assisted for safe operation

Chain driven assembly

Windbars provide added wind protection

Strong guiderails

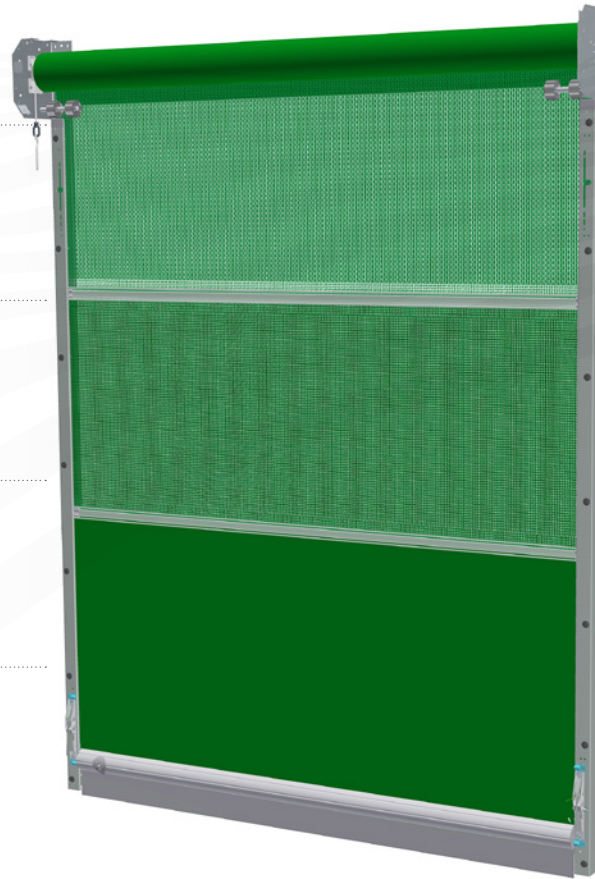

Strong, single phase tubular motor giving opening speed of 9sec/m



AD10 controller



Easy to operate hold to run switches

- Choice of panels which can be replaced easily in event of accidental damage
- Agridoor Comfort features manual override facility in case of power cut
- Fully automatic locking catches

** Not available in the UK*



Agridoor Electric Premium

Spring assisted for safe operation

Chain driven assembly

Windbars provide added wind protection

Strong guiderails

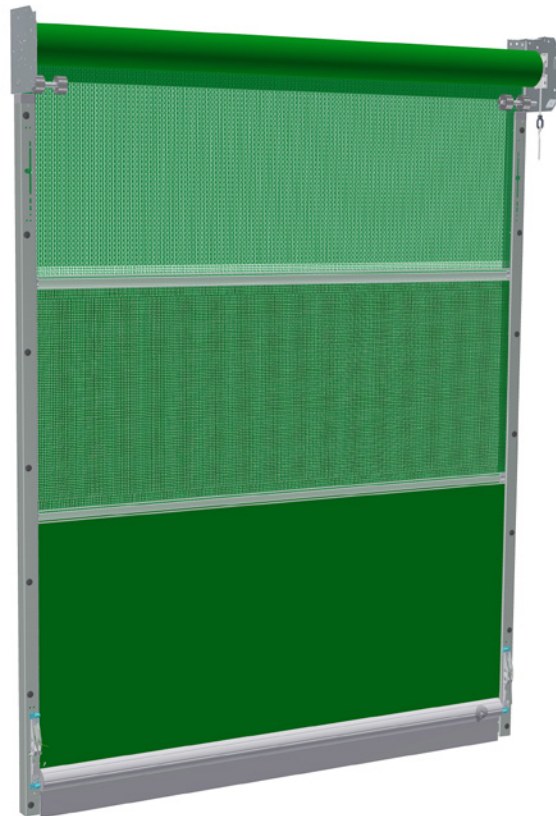

Strong, single phase tubular motor giving opening speed of 9sec/m



AD10 controller



Remote control



Easy to operate hold to run switches

- Choice of panels which can be replaced easily in event of accidental damage
- Agridoor Premium features waterproof remote control and can control up to 8 doors with just one controller

- Fully automatic locking catches
- Agridoor Premium includes built in safety edge prevents doors closing on obstacles



GALEBREAKER
AGRIDOOR
✓ Betriebssicherheit
✓ Dauerbelastung
DLG-Prüfbericht 6919

Agridoor Plus

Designed specifically for feed stores, grain stores and general purpose buildings requiring larger access openings. All the benefits of Agridoor Electric but available up to 10m high or up to 10m wide with a maximum door size of 55m². Top rolling for maximum clearance, does not require locking catches and has a built-in safety brake. Electronic limits set at ground level, manual override. External motor with extended duty cycle.



Heights from 5m to 10m | Widths from 5m to 10m

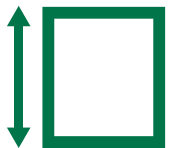

Fully adjustable



Robust



Sectional door



10 year warranty

Robust door designed for large, exposed locations

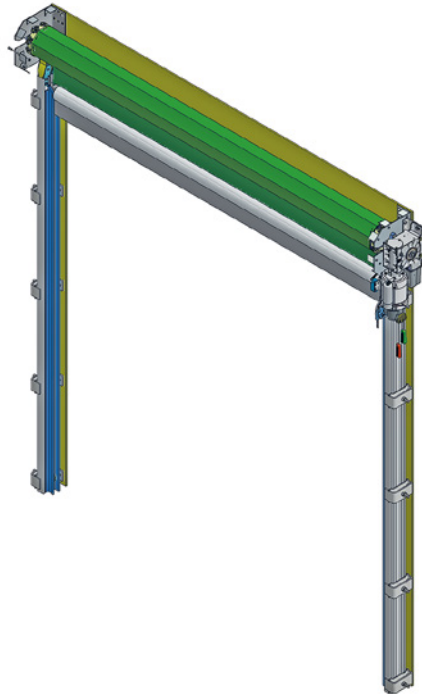
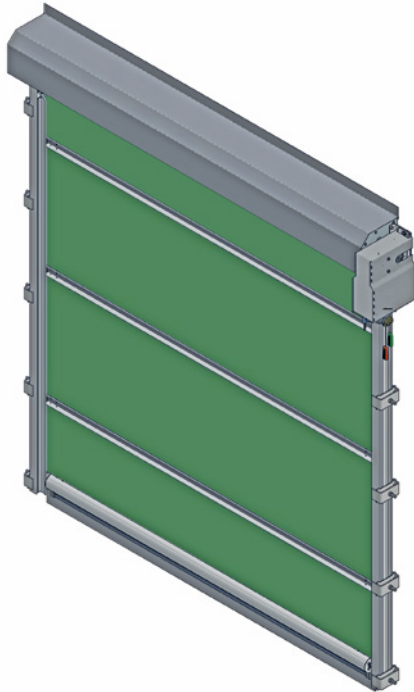

Single or three phase motor options, with built-in safety brake.

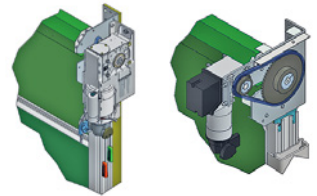

Direct or indirect motor options allow multiple doors to be mounted in series.

- Choice of materials and colours for each door panel
- Right or left hand drive
- Hold to run or remote control options
- Cowling included, as standard
- External motor with fast opening speed of 7sec/m
- Can mount multiple doors in line



Maxidoor[®]

Galebreaker's Maxidoor folding door system provides weather protection and ventilation for large openings of up to 20 metres wide. Allowing for full width access and maximum convenience, the Maxidoor is easily operated, even in high winds.

Designed for multi-purpose use, suitable for grain storage, feed stores, livestock buildings and general purpose agricultural buildings.



Heights up to 10m | Widths up to 20m

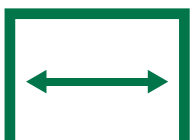

Wide openings



Motorised



Flexible weather protection



10 year warranty

Folding door up to 20m wide

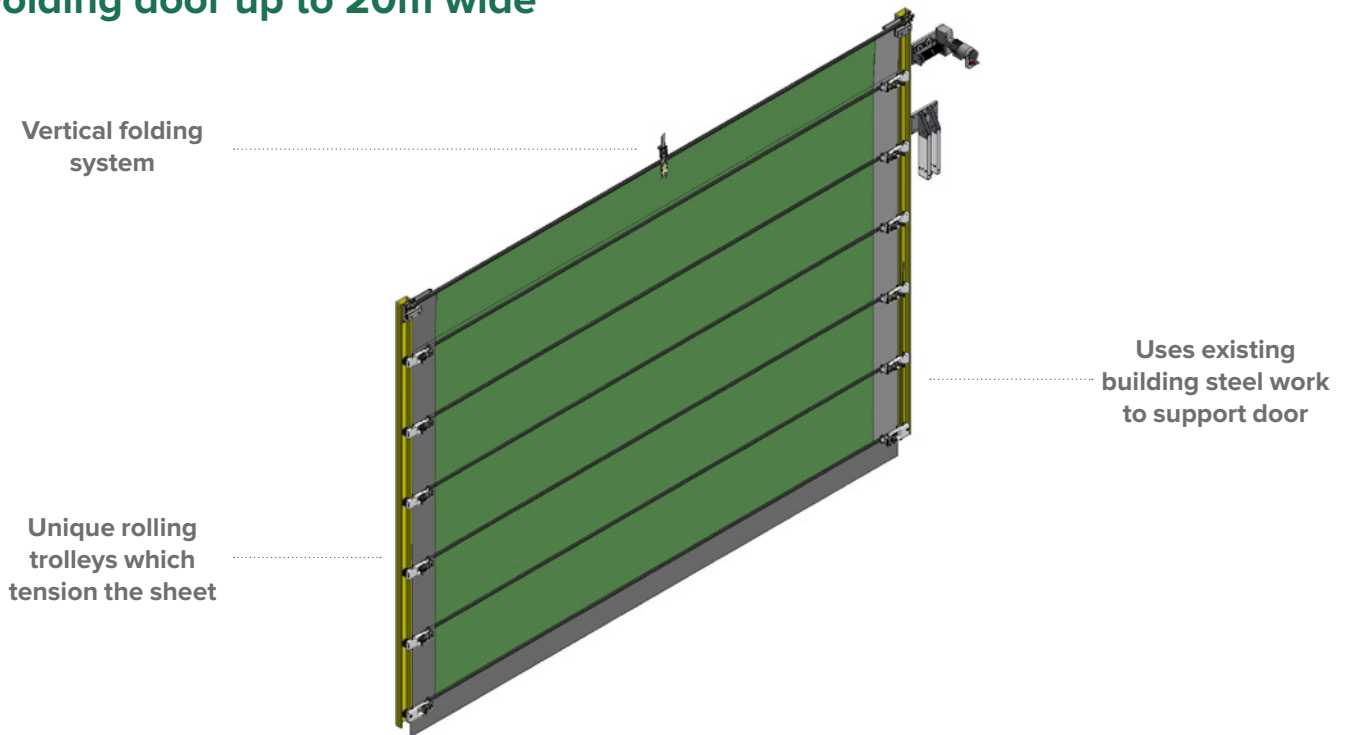

- Left or right operating
- Range of material and colour options available
- Single or three phase motor options available

Please note: There is a 20% loss in opening height when the door is fully open



Trackscreen

Trackscreen is Galebreaker's sliding curtain door system, which runs on overhead tracking and provides weather protection and ventilation for farm buildings with wide openings. Allowing for the full access height to be maintained, and with an additional sliding post option available to allow access from both ends, it does not require any ground fixing and complies with EC door directive EN-13241. It is suitable for grain storage, feed stores, livestock buildings and general purpose agricultural buildings.



Heights up to 5m | Widths up to 20m



Maintain full height access



Self fit



Fast fit



10 year warranty

Sliding curtain door system

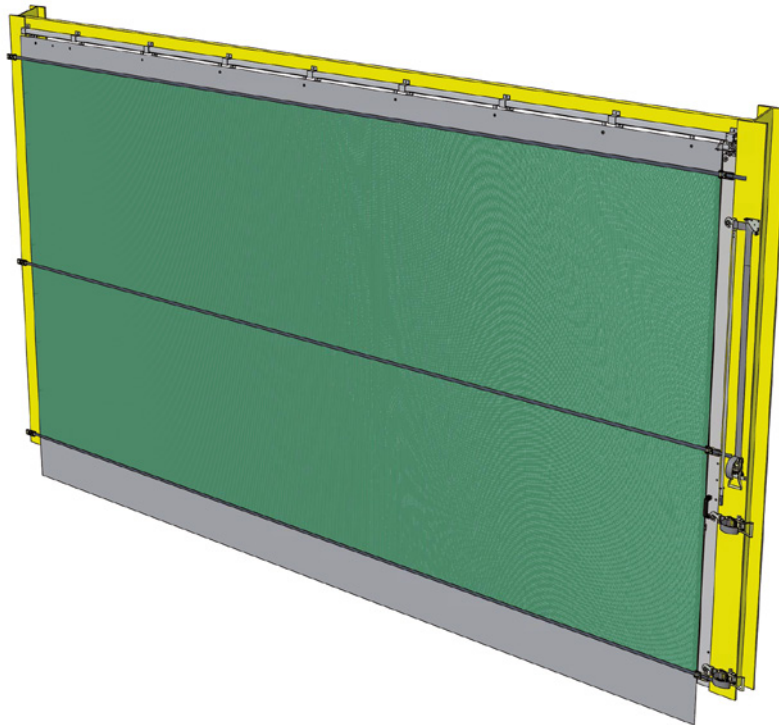

- Range of material and colour options available
- Left or right hand operation, or additional sliding post allows access from both ends
- Track either fitted to the underside of the lintel or the front of the lintel
- Around 12% opening loss when screen is fully open



Multibay[®]

Multibay is Galebreaker's electric, rolling agricultural door system, providing access, ventilation and weather protection to multiple bays in a single run. It has a safety clutch included to meet the EC door directive, unique locking catches, and it has different fabric and colours options available to help maximise air circulation for livestock.



Heights up to 6m | Widths up to 70m



**Regular access
required**



**Value for
money**

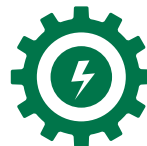

Motorised



**10 year
warranty**

Electronic rolling system for multiple bays



Locking catches keep sheet tight, even during high winds

- Range of material and colour options available
- Fewer control tubes allow more space for access
- Safety measures included to meet EC door directive
- Simple hold to run operation



Scan for
installation
instructions



VentTube Fresh

VentTube Fresh is a positive pressure tube ventilation system designed to provide a calculated supply of fresh, equally dispersed air at animal level to remove moisture, airborne pathogens, and excess heat from livestock environments. Air exits the tube at a low velocity ensuring that the environment is fresh and clean, but without creating a draught.



With a VentTube Fresh installation, your livestock will benefit from:



A significant improvement in air quality which can help reduce cases of respiratory disease*



Fresh air delivered to the micro-environment of the calf without creating a draught



The systematic removal of moisture, gases, airborne pathogens and excess heat

* Radostits et al., 2000; Callan and Garry, 2002.

Custom designed

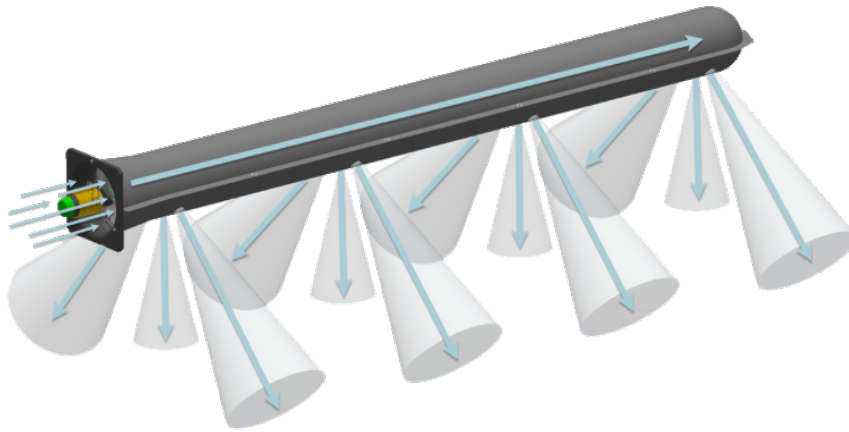

Galebreaker designs and manufactures a bespoke tube, based on a range of factors including number and age of livestock, dimensions of building and location.

- Designed by experts, VentTube comprises an outside mounted fan connected to a fabric tube, which has air openings at strategic positions
- This allows evenly distributed clean fresh air to exit the tube along its length
- Each product is individually specified for each installation, ensuring suitability
- Rapid air exchanges per hour, year round, for optimal air circulation



VentTube Cool

VentTube Cool provides an all-in-one solution for eliminating heat stress produced by poor ventilation in livestock barns and sheds. By increasing the volume and velocity of air flowing out of the tube, a chill effect can be produced. With an innovative retraction system that hoists up the tube when not in use, VentTube Cool distributes clean, cool air over large areas and maintains optimal temperatures for both increased animal comfort and productivity.



With a VentTube Cool installation, your livestock will benefit from:



**Fresh, cool air
equally distributed
across either cubicles
or open plan buildings**



**Improved overall
welfare, which
will translate into
productivity gains**



**The ability of VTC to create
a chill effect during the
summer months or help
with improving air quality
during winter months**

Custom designed

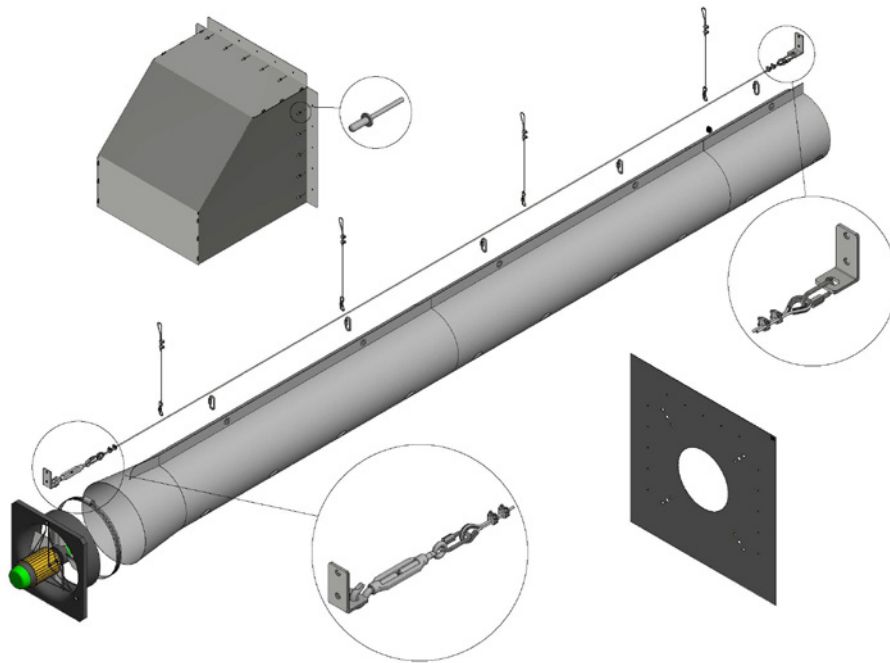

- Designed by experts, VentTube comprises an outside mounted fan connected to a fabric tube, which has air openings at strategic positions
- This allows evenly distributed clean fresh air to exit the tube along its length
- Each product is individually specified for each installation, ensuring suitability
- Rapid air exchanges per hour, year round, for optimal air circulation
- Industrial-grade fabric, used to manufacture each Tube



Variable Ventilation Systems (VVS)[®]

Galebreaker's VVS is designed to be the ultimate in natural building ventilation. Providing the best of both worlds by optimising natural air flow whilst protecting livestock from the elements.

VVS side curtain systems are powered by VentLogic technology, our automatic control systems make use of temperature, wind speed, wind direction and rain sensors to ensure that the climate within the building is continually optimised.

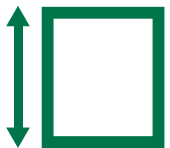

Fully adjustable



Fully automated



Flexible weather protection



10 year warranty

Flexible and adaptable side curtain ventilation, fully integrated with the iSeries

Galebreaker has 4 VVS models; VVS Rolling, VVS Climbing, VVS Drop and VVS Shade, each operating in a slightly different way and can be used with one of our Controllers (see page 41).

VVS Rolling

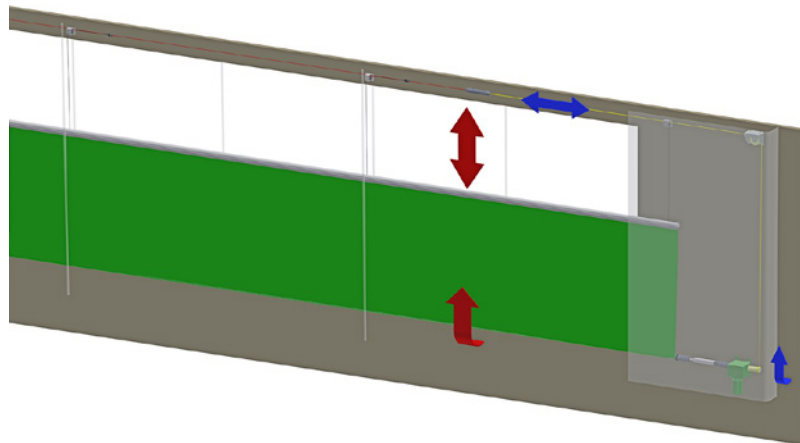

- Opens from the top, with the fabric rolling on to a tube at the bottom or middle (depending on the height of the opening)
- Optional bird proof seal
- Brings in fresh air without creating a draught at animal level
- Range of colours and fabric available – suiting planning and livestock requirements
- Cable or torque drive – offering long service life
- Manual or fully automated options available



Height up to 5m | Widths up to 140m



Scan to see the VVS in action



VVS Climbing

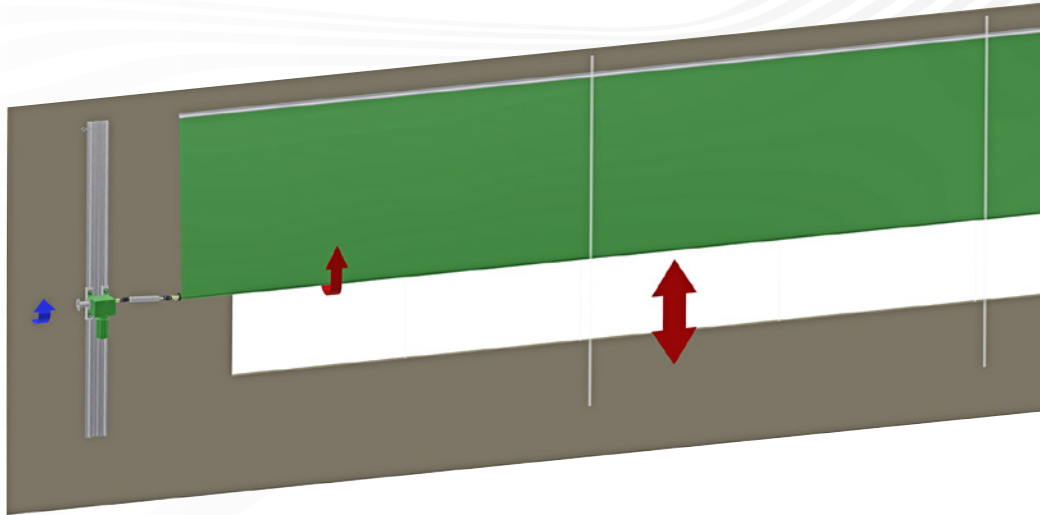

- Opens from the bottom, with the fabric rolling on to a top or middle tube, depending on the opening height
- Ideally suited to buildings with no overhang, providing full weather protection
- Integrates with full range of controllers
- Ideal for beef cattle and livestock which need a fresh air along their back
- Manual or fully automated options available



Height up to 3m | Widths up to 140m



VVS Drop

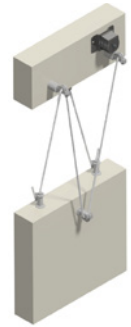
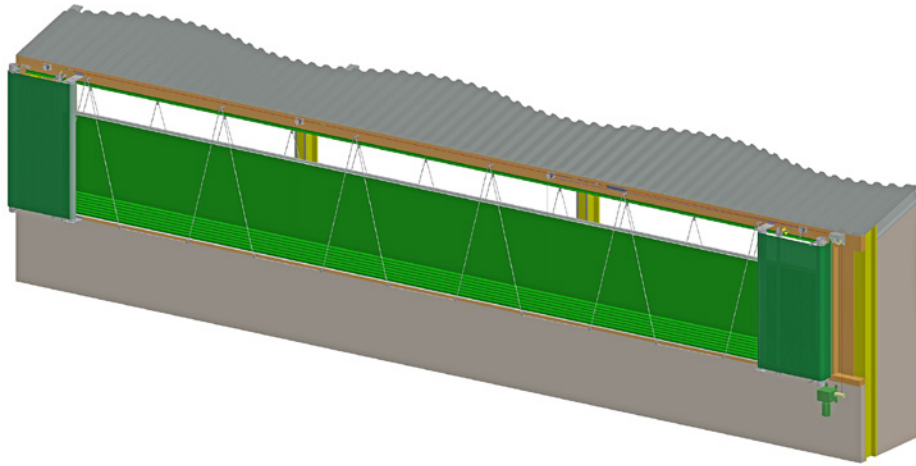

Supplied with cable control.

- Economical, side curtain
- System uses gravity to open the curtain and pleat at the bottom of the opening
- Curtains can be closed either by using a hand winch or motor
- Manual or fully automated options available
- Ideal system for Farmers blowing bedding (chopped straw, sand, wood dust) in through the open side curtain
- Maximum length for hand operated systems is 70m long and 3m high; maximum length increases to 140m when driven by a motor



Height up to 3m | Widths up to 140m



VVS Shade

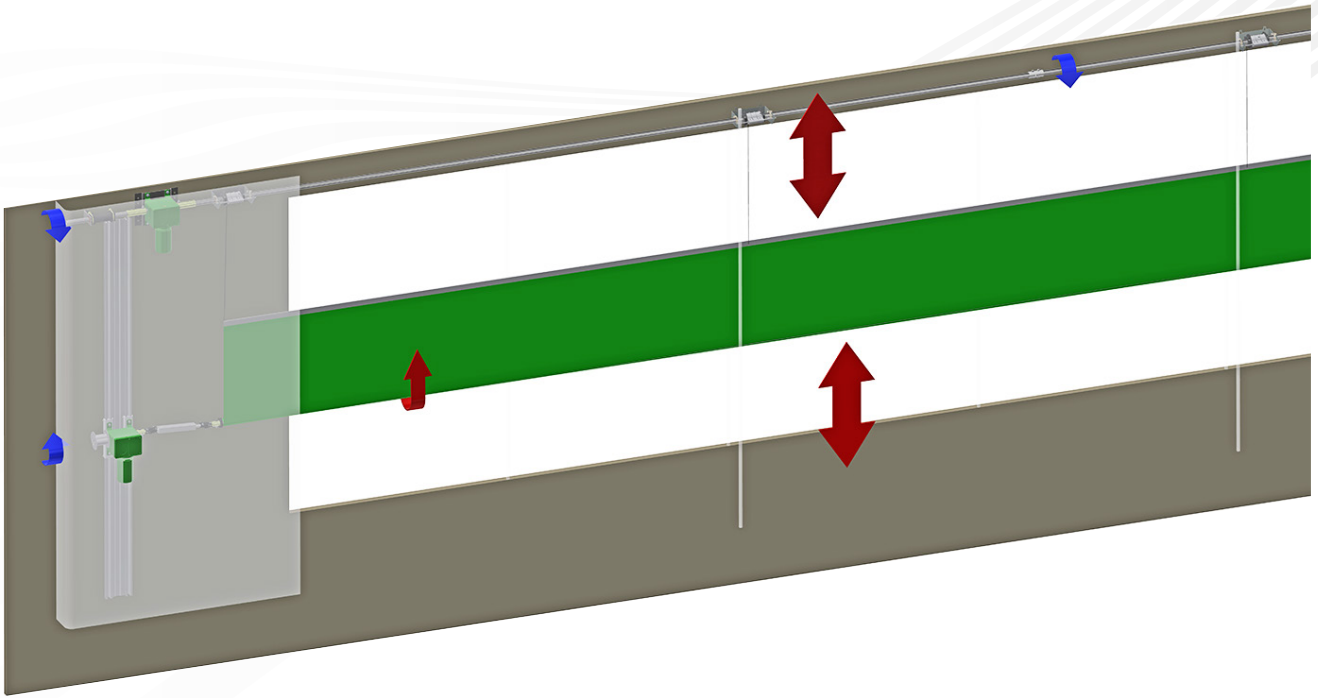

- Curtain opens from the top and bottom allowing airflow to be directed precisely into the building
- Shade function not available with iSeries
- Fully automated options available



Height up to 3m | Widths up to 140m



VVS[®] Controllers

Manual Drive – Double axle gearbox with telescopic shaft

A cost-efficient and effective way to control and position VVS side curtain systems. Can be supplied either with a crank handle or can be chain driven.



- Low cost
- Self braking, allows curtains to come to rest in any position
- Can be supplied with a crank handle or, for installations where the system is at high level, can be chain driven
- Suitable for use with manually operated R7 (rolling) and B6 (Basic) VVS Systems
- Not available for use with torque tube systems



Hold to run switch

Hold to run is a safety feature which only allows the curtain to move when the operator turns and holds the switch. If the switch is released the curtain stops moving. The curtain can come to rest in any position. Suitable for use with all electrically operated VVS systems.

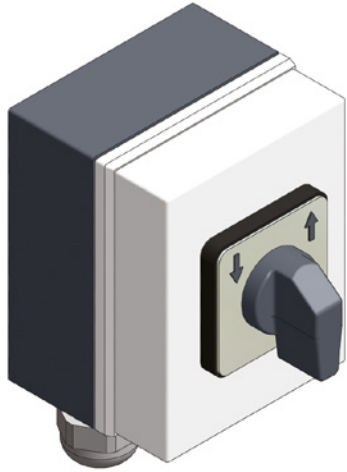

- Basic control for electrically operated systems
- Improve safety and control of all VVS systems
- Easy to install
- Minimise risk



V40

The VentLogic V40 is designed for full automation of electrically operated side curtain systems. VVS curtain positioning is completely controlled by temperature, wind speed, wind direction and rain sensors to ensure that the climate within the building is continually optimised. One V40 can control up to four openings and each opening can have different parameter settings for total flexibility.



- Pulse-Pause and emergency stop safety features
- In addition to the curtain operation, two auxiliary systems can be activated if temperature thresholds are reached
- Suitable for use with electrically operated VVS Systems
- Designed to operate a Galebreaker ventilation system automatically in response to signals from environmental sensors
- Controls the ventilation system in a safe and controlled manner without the operator in attendance
- Does not require feedback from a potentiometer fitted to the drive motor
- Not intended for use on access door systems



iSeries

The VentLogic iSeries is an unprecedented leap in smart farm building control, designed to provide the optimal conditions for livestock health and growth. Powered by intelligent automation, the iSeries responds in real-time to changes in weather and environmental conditions to ensure the highest levels of productivity and animal wellbeing.

iSeries



Control Remotely

Automatically optimise the environment based on pre-set parameters, such as temperature, humidity and light level.



Critical Alarms

Optional subscription packages provide you with alerts and alarms, even when off farm.



Traceability

Demand for total traceability of the supply chain makes it important to measure and monitor livestock conditions.



Future-Proofing

Integrating with numerous systems & sensors meaning farmers can be assured of 'future-proofing' their business.

The iSeries is composed of five core elements. Operating together, they offer you a comprehensive and holistic view of your farm.

iSeries Sensors

Full range of sensors, including wireless sensors, enabling you to optimise your building. Capture valuable data, including wind speed, temperature, ammonia and carbon dioxide levels.

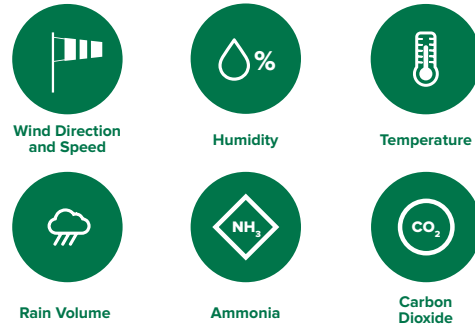

iSeries Controllers

Integrate multiple buildings and monitoring systems. iSeries has a broad plug and play compatibility allowing you to integrate with third party products. Add buildings or zones in the future as you grow.

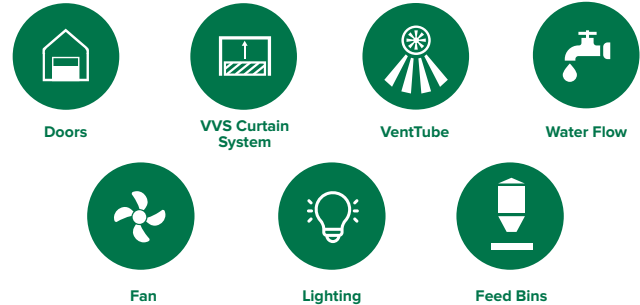

iSeries Monitor and Control Devices

Automatic control of VVS side curtains, fans, doors, lighting, VentTubes and more.



iSeries App

See real time information from each zone on your mobile device or tablet. Optimise multiple building environments according to weather conditions and the needs of your livestock.

iSeries Reports and Analysis

Get comprehensive reports on system and building performance, enabling you to make clear and consistent improvements to farm conditions.



Light Ridge

Designed to improve ventilation in livestock buildings by providing an exit path for warm stale air while, at the same time, improving light transmission into the building.

Healthier environment for animals, an increase in natural light, and reduces the risk of diseases such as pneumonia, mastitis and scours.

Toughened waterproof PVC roof panels and tailored wind guide plates can withstand almost any weather conditions, and the simple design makes the Light Ridge easy to fit to new or existing buildings.



Widths available: 1m, 2m, 3m



**Maximise
livestock
ventilation**



**Improved
natural light**



**No fans or
moving parts**



**10 year
warranty**

Active ventilation improvement

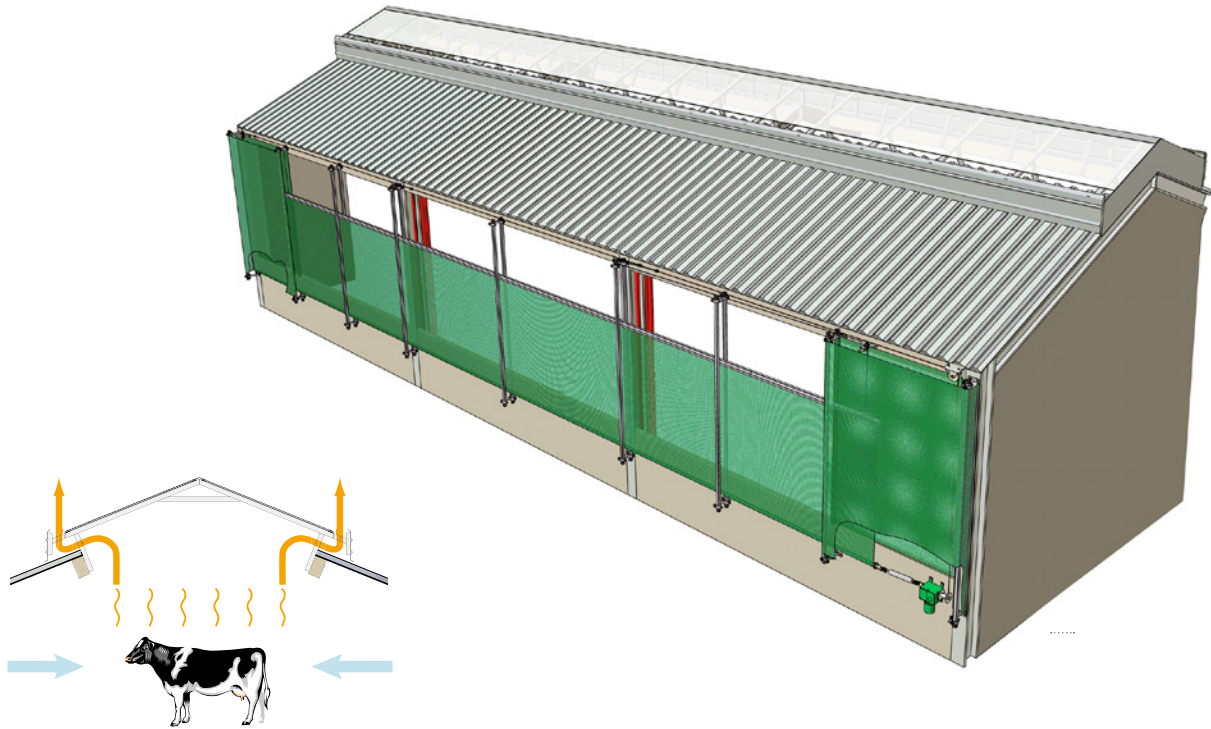

- Used in conjunction with VVS, can help provide total ventilation control
- Air outlet - 600mm
- Optional coloured baffles



Fixed Systems

Farmflex

Galebreaker mesh material is available off-the-roll for a wide range of applications. A DIY screening solution providing fixed systems for weather protection and ventilation in agricultural buildings. A superior and lower cost alternative to Yorkshire boarding and space boarding. The ideal sheet material for DIY windbreakers or side cladding.

- Range of material and colour options available



Widths up to 3m



**Maximise
livestock
ventilation**



Self fit



**Flexible
weather
protection**



**Meets
quality assurance
standards**

Stockshade

Easy to install lightweight material with 70% shade factor for livestock welfare.

Galebreaker's livestock shading material is specially designed to provide protection from sunburn in outdoor reared pigs. Livestock shading is also important to the welfare of chickens and other poultry.



Sizes available: 3m x 4m; 4.5m x 4m; 6m x 4m

Scan to see
Stockshade
in action



Off the roll solutions...

Rigitex

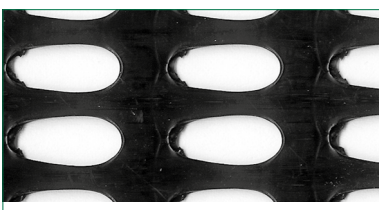

An extruded plastic windbreak in roll form. The economical answer for DIY installation.

Bird Net



14mm strong extruded mesh ideal for bird-proofing grain and feed stores.

PVC Strip

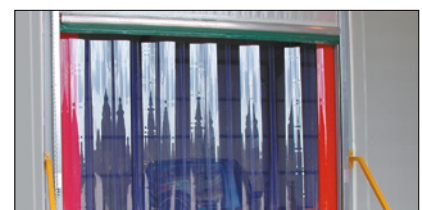

Strip available in 50m rolls for DIY installation. Various sizes available.

SilaCover

Heavy duty (300g/m²) woven polyethylene covers with extra strong hemmed edges. Galebreaker sheets negate the need for tyres and reduces spoilage due to the systems ability to drive out aerobic fermentation from the silage clamp.

- Woven polyethylene with hemmed edges
- Protects polythene under-sheet
- Reduces spoilage
- Bag fixing loops as standard



Sizes available: 16m x 5m; 12m x 10m; 12m x 15m; 20m x 10m; 25m x 12m



**Free SilaBags
(UK only)**



**Full protection
from birds and
mammals**



Easy handling



**10 year
warranty**

Customer Services

Spares and fixings

Spares and fixings for the complete range of Galebreaker products are available off-the shelf from our Ledbury facility.

Because all our systems are manufactured here in UK we can pack, ship and deliver spares and fixings quickly and accurately.



Installation

Most Galebreaker products are delivered in kit form and can be quickly and easily installed by the customer. Full fitting instructions are supplied.

If required, and for an additional charge, Galebreaker offer a comprehensive installation service.

How to measure for doors

Measure gap A i.e. the daylight gap between the uprights. If the measurement falls between the Galebreaker sizes shown in the price list choose the next size up as widths can be adjusted.

Measure gap B i.e. the daylight gap and choose the nearest size up to suit.

If you need clarification call the sales office with metric daylight measurements.

All sizes are based on daylight gap.

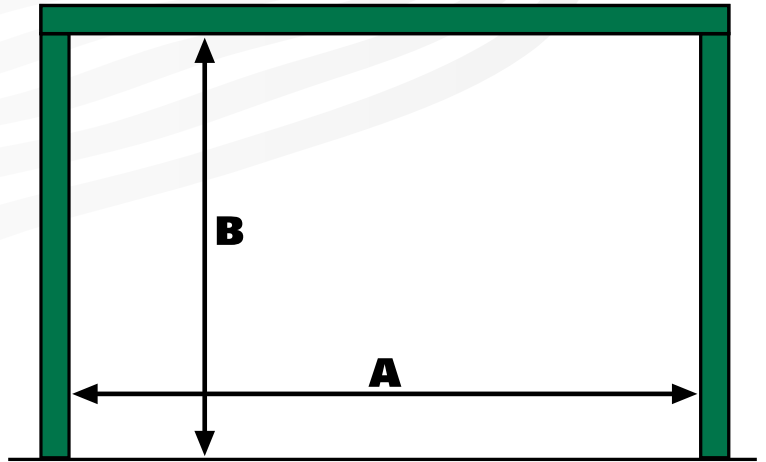



CE Door Directive

CE Marking Door Regulations. Since 2005 Galebreaker have been CE marking both manual and electric doors. For powered / electric doors this was done following the procedures and guidelines detailed in EN13241. Galebreaker used the information detailed in EN13241 to streamline their design process to mitigate risk and so were able to also CE mark manual doors.

Declaration of Performance documents for Galebreaker products are available on the Galebreaker Agri website in the customer support area. All Galebreaker doors are sold with the expectation that they will be operated by trained users in a controlled area. Agridoor Electric models are fitted with a highly sensitive safety edge system.

Galebreaker are members of the Door & Hardware Federation. Choosing a CE marked product from a DHF member company means that the CE mark is evidence of compliance relating to product safety under health and safety legislation – and so it helps protect the architect's or specifier's client against litigation in the event of an accident occurring.

EN 13241 also includes a wind load classification system which all Galebreaker Door Systems adhere to. For further details about the wind damage policy visit the Galebreaker Agri website.



Fabrics

As a leader in fabric-engineering solutions, Galebreaker has a range of robust and long lasting materials, optimised for ventilation, weather protection and light transmission.

All materials are:



Rot Proof



Non toxic



**Tear
resistant**



**UV
stabilised**



**Flame
retardancy to
EU standards**

Our mesh material cannot be torn or ripped. When cut they do not fray due to the PVC coating which is applied.

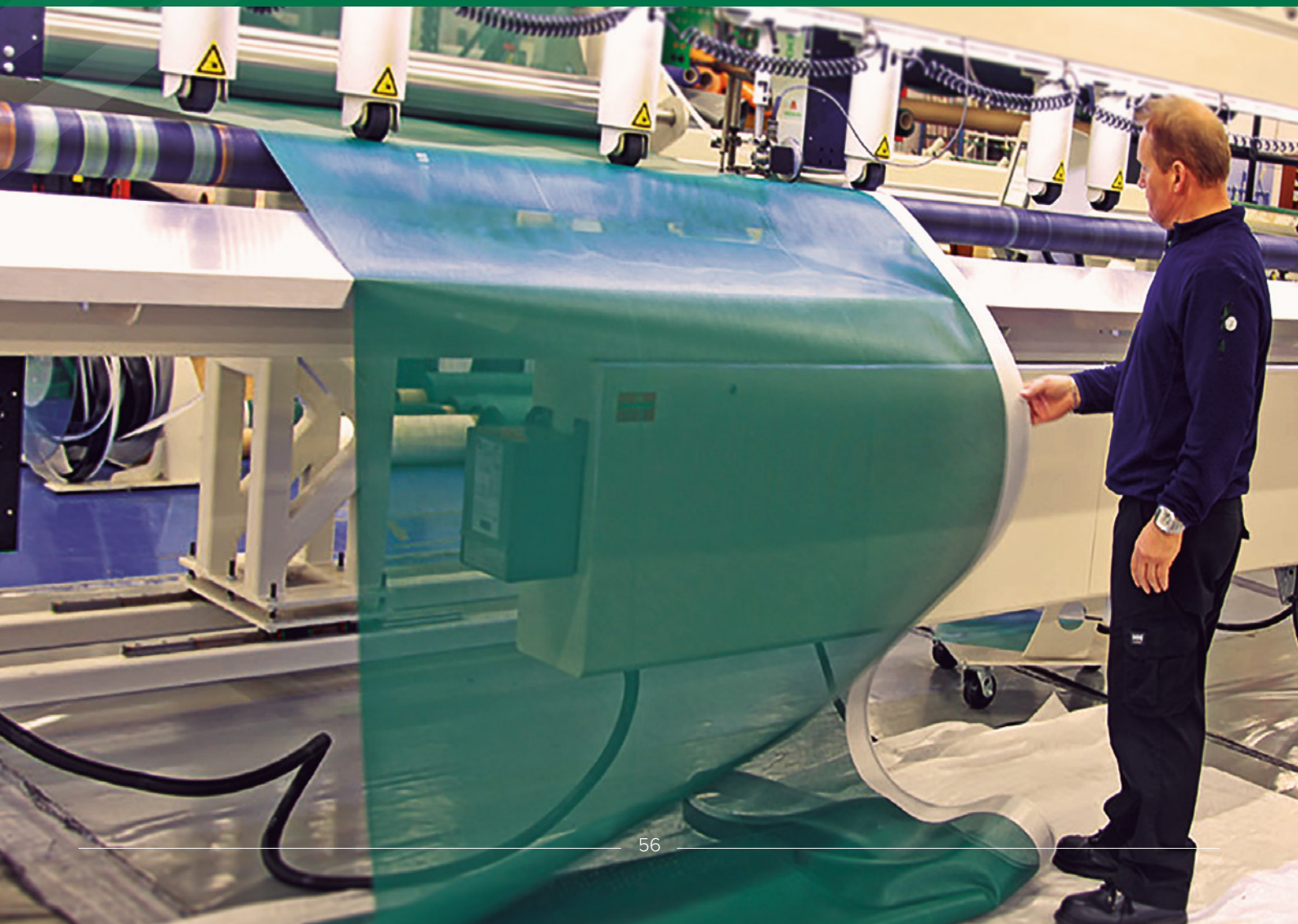

Mesh Materials

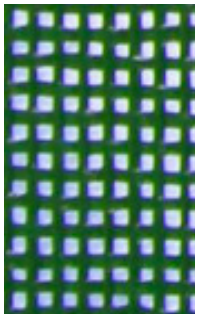

M75 Standard

- PVC coated polyester
- 3.3 tonnes/m tensile strength
- Approx 25% permeable
- Flame retardant to European standards M1

Colour range:

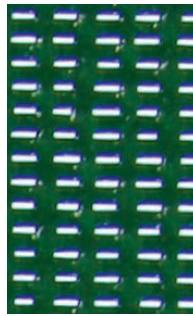
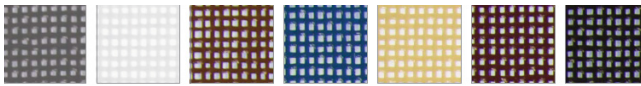

M90 High Performance

- PVC coated polyester
- 3.4 tonnes/m tensile strength
- Non-permeable
- Flame retardant to European standards M2 and B1

Colour range:

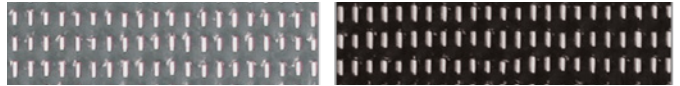

Solid Materials

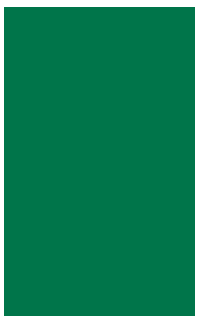

S68 Solid

- PVC coated polyester
- 5 tonnes/m tensile strength
- Non-permeable
- Flame retardant to European standards M2 and B1

Colour range:

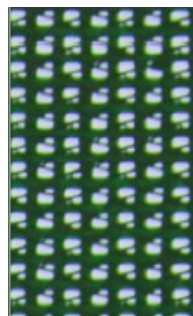

ST55 Solid Translucent

- PVC coated polyester
- 3.4 tonnes/m tensile strength
- Non-permeable
- Flame retardant to European standards M2 and B1

Colour range:



Product Specific Materials

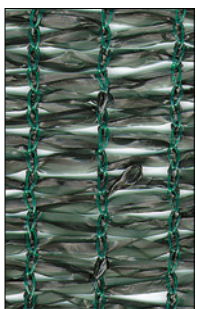

Stockshade

- HD polythene
- 70% shade



SILA-COVER® 300

- HD woven polythene
- Gross weight 300g/m²
- 3 tonnes tensile strength

Notes



Notes



Contact Galebreaker on
+44 (0) 1531 637900

Galebreaker House,
New Mills Industrial Estate,
Ledbury, Herefordshire, HR8 2SS
United Kingdom

E: marketsupport@galebreaker.com
www.galebreaker.com

Made  Herefordshire 04.2021

Galebreaker[®]
AGRI

Your Guard Against the Elements